

## PRECISE MEASURING AMPLIFIER CL 100P

- High accuracy
- High protection degree – IP65
- High durability
- Operating temperature  $-25 \div 65^{\circ}\text{C}$
- Supply 24 V dc, 220 V AC – four-lead line
- Automatic compensation of cable length influence
- Three year warranty and after market service
- CE conformity



Precise measuring amplifier CL 100P is assigned for use with strain gauge sensors with  $120 \div 1200 \Omega$  full bridge. It is especially suitable for applications in difficult climatic and mechanical environment. This amplifier is assigned for industrial use and other environments demanding high protection against dust, vibrations and humidity.

### Specifications

Type		CL 100P
Gain*	V/V	50÷1000
Transfer band*	Hz	10÷200
Fluent gain adjustment*	%	$\pm 5 (\pm 1 \div \pm 10)\%$
Supply voltage	V	5 or 10
Minimal resistance of sensor set	$\Omega$	80 for 10 V supply
	$\Omega$	40 for 5 V supply
Max. cable length (to sensor)	m	30
Long term instability of output signal	%/month	$\leq 0,1$
Nonlinearity	%	$\leq 0,05$
Temperature gain coefficient	%/10 <sup>°</sup> C	$\leq 0,05$
Temperature creep of output signal	%/10 <sup>°</sup> C	$\leq 0,05$
Operating temperature	°C	$-40 \div +85$
Input Resistance	G $\Omega$	symmetric $\geq 10$
Asymmetric output:		
voltage	V	$\pm 10$ max.
output resistance	$\Omega$	1
maximal current	mA	20
current	mA	0÷20 or 4÷20
maximal load resistance	$\Omega$	500
Supply:		
voltage	V AC	230 / 50Hz
current – continuous use	A	0,1

\*Parameter determined inside of amplifier regarding order.

## Quality assurance

Each amplifier is examined internally before sale.

Producer offers 36 month warranty and after market service.

Diameters:

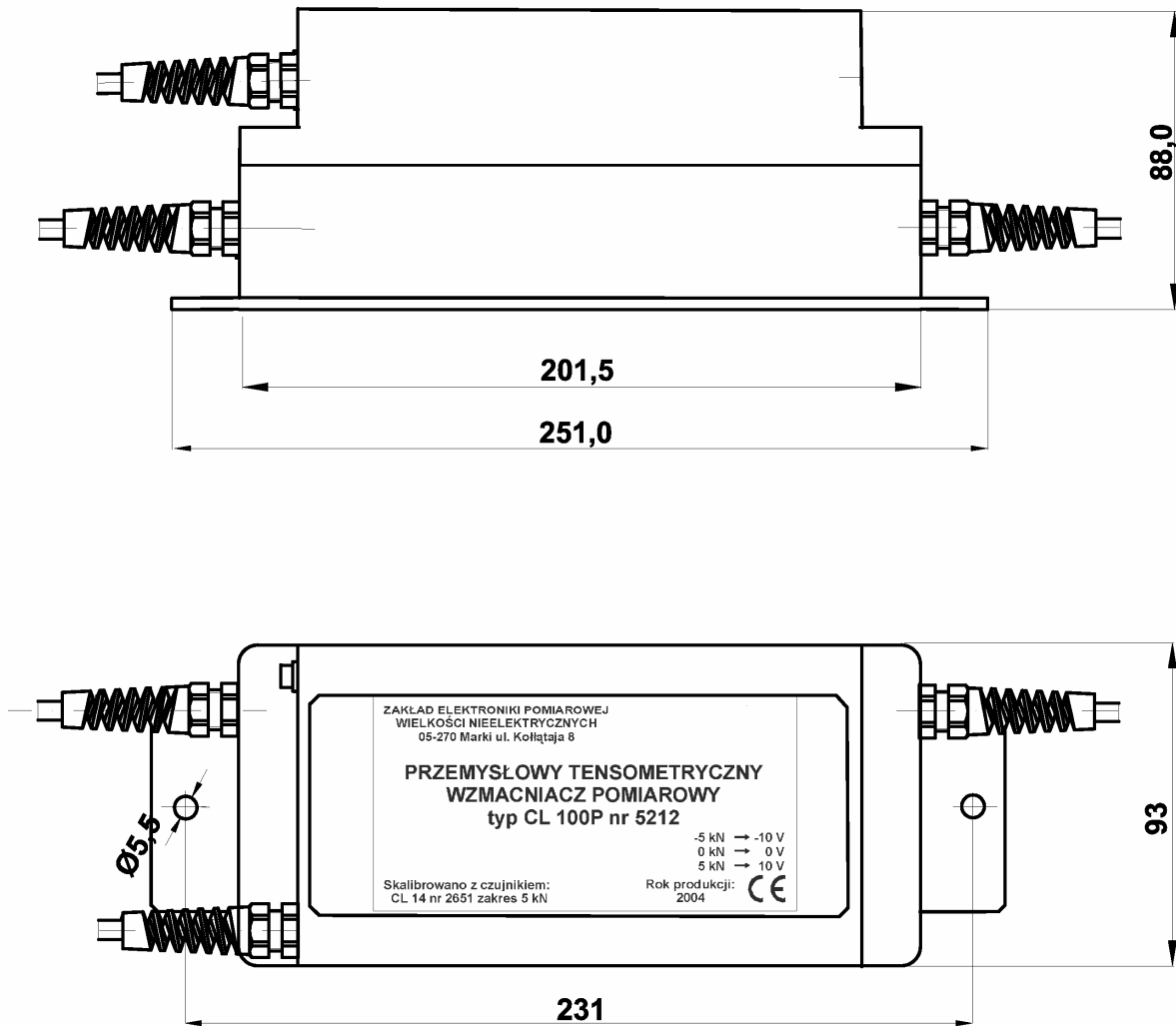

Manufacturer: \_\_\_\_\_

Zakład Elektroniki Pomiarowej Wielkości Nielektrycznych, 05-270 Marki, ul. Kołłątaja 8  
tel./fax: (004822) 7812169, 7712411, e-mail: [zepwn@zepwn.com.pl](mailto:zepwn@zepwn.com.pl), <http://www.zepwn.com.pl>

## PRECISE MEASURING AMPLIFIER CL 100P

- High accuracy
- High protection degree – IP65
- High durability
- Operating temperature  $-25 \div 65^{\circ}\text{C}$
- Supply 24 V dc, 220 V AC – four-lead line
- Automatic compensation of cable length influence
- Three year warranty and after market service
- CE conformity



Precise measuring amplifier CL 100P is assigned for use with strain gauge sensors with  $120 \div 1200 \Omega$  full bridge. It is especially suitable for applications in difficult climatic and mechanical environment. This amplifier is assigned for industrial use and other environments demanding high protection against dust, vibrations and humidity.

### Specifications

Type		CL 100P
Gain*	V/V	50÷1000
Transfer band*	Hz	10÷200
Fluent gain adjustment*	%	$\pm 5 (\pm 1 \div \pm 10)\%$
Supply voltage	V	5 or 10
Minimal resistance of sensor set	$\Omega$	80 for 10 V supply
	$\Omega$	40 for 5 V supply
Max. cable length (to sensor)	m	30
Long term instability of output signal	%/month	$\leq 0,1$
Nonlinearity	%	$\leq 0,05$
Temperature gain coefficient	%/10 <sup>o</sup> C	$\leq 0,05$
Temperature creep of output signal	%/10 <sup>o</sup> C	$\leq 0,05$
Operating temperature	<sup>o</sup> C	$-40 \div +85$
Input Resistance	G $\Omega$	symmetric $\geq 10$
Asymmetric output:		
voltage	V	$\pm 10$ max.
output resistance	$\Omega$	1
maximal current	mA	20
current	mA	0÷20 or 4÷20
maximal load resistance	$\Omega$	500
Supply:		
voltage	V AC	230 / 50Hz
current – continuous use	A	0,1

\*Parameter determined inside of amplifier regarding order.

## Quality assurance

Each amplifier is examined internally before sale.

Producer offers 36 month warranty and after market service.

Diameters:

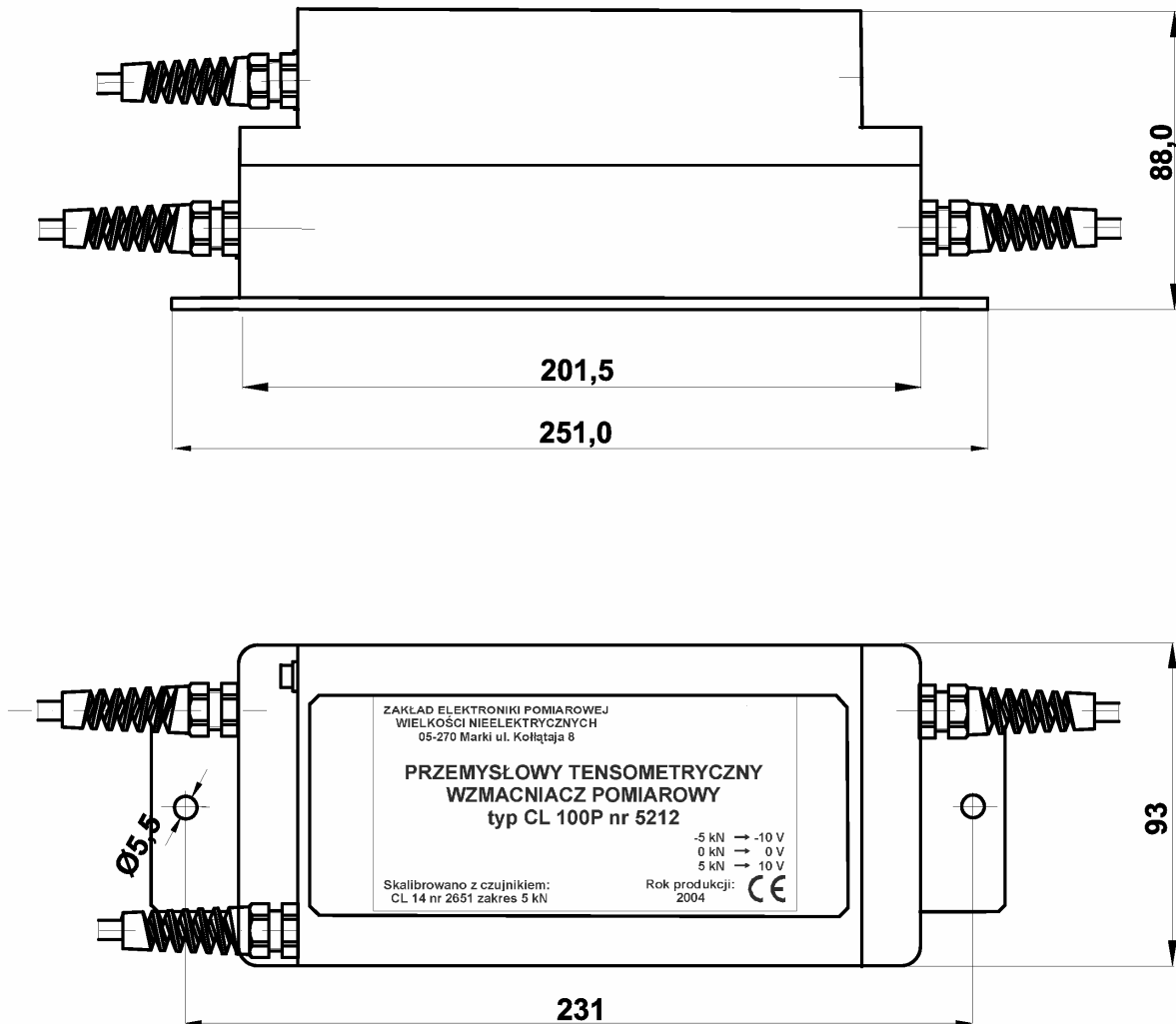

Manufacturer: \_\_\_\_\_

Zakład Elektroniki Pomiarowej Wielkości Nielektrycznych, 05-270 Marki, ul. Kołłątaja 8  
tel./fax: (004822) 7812169, 7712411, e-mail: [zepwn@zepwn.com.pl](mailto:zepwn@zepwn.com.pl), <http://www.zepwn.com.pl>

## PRECISE MEASURING AMPLIFIER CL 100P

- High accuracy
- High protection degree – IP65
- High durability
- Operating temperature  $-25 \div 65^{\circ}\text{C}$
- Supply 24 V dc, 220 V AC – four-lead line
- Automatic compensation of cable length influence
- Three year warranty and after market service
- CE conformity



Precise measuring amplifier CL 100P is assigned for use with strain gauge sensors with  $120 \div 1200 \Omega$  full bridge. It is especially suitable for applications in difficult climatic and mechanical environment. This amplifier is assigned for industrial use and other environments demanding high protection against dust, vibrations and humidity.

### Specifications

Type		CL 100P
Gain*	V/V	50÷1000
Transfer band*	Hz	10÷200
Fluent gain adjustment*	%	$\pm 5 (\pm 1 \div \pm 10)\%$
Supply voltage	V	5 or 10
Minimal resistance of sensor set	$\Omega$	80 for 10 V supply
	$\Omega$	40 for 5 V supply
Max. cable length (to sensor)	m	30
Long term instability of output signal	%/month	$\leq 0,1$
Nonlinearity	%	$\leq 0,05$
Temperature gain coefficient	%/10 <sup>o</sup> C	$\leq 0,05$
Temperature creep of output signal	%/10 <sup>o</sup> C	$\leq 0,05$
Operating temperature	°C	$-40 \div +85$
Input Resistance	G $\Omega$	symmetric $\geq 10$
Asymmetric output:		
voltage	V	$\pm 10$ max.
output resistance	$\Omega$	1
maximal current	mA	20
current	mA	0÷20 or 4÷20
maximal load resistance	$\Omega$	500
Supply:		
voltage	V AC	230 / 50Hz
current – continuous use	A	0,1

\*Parameter determined inside of amplifier regarding order.

## Quality assurance

Each amplifier is examined internally before sale.

Producer offers 36 month warranty and after market service.

Diameters:

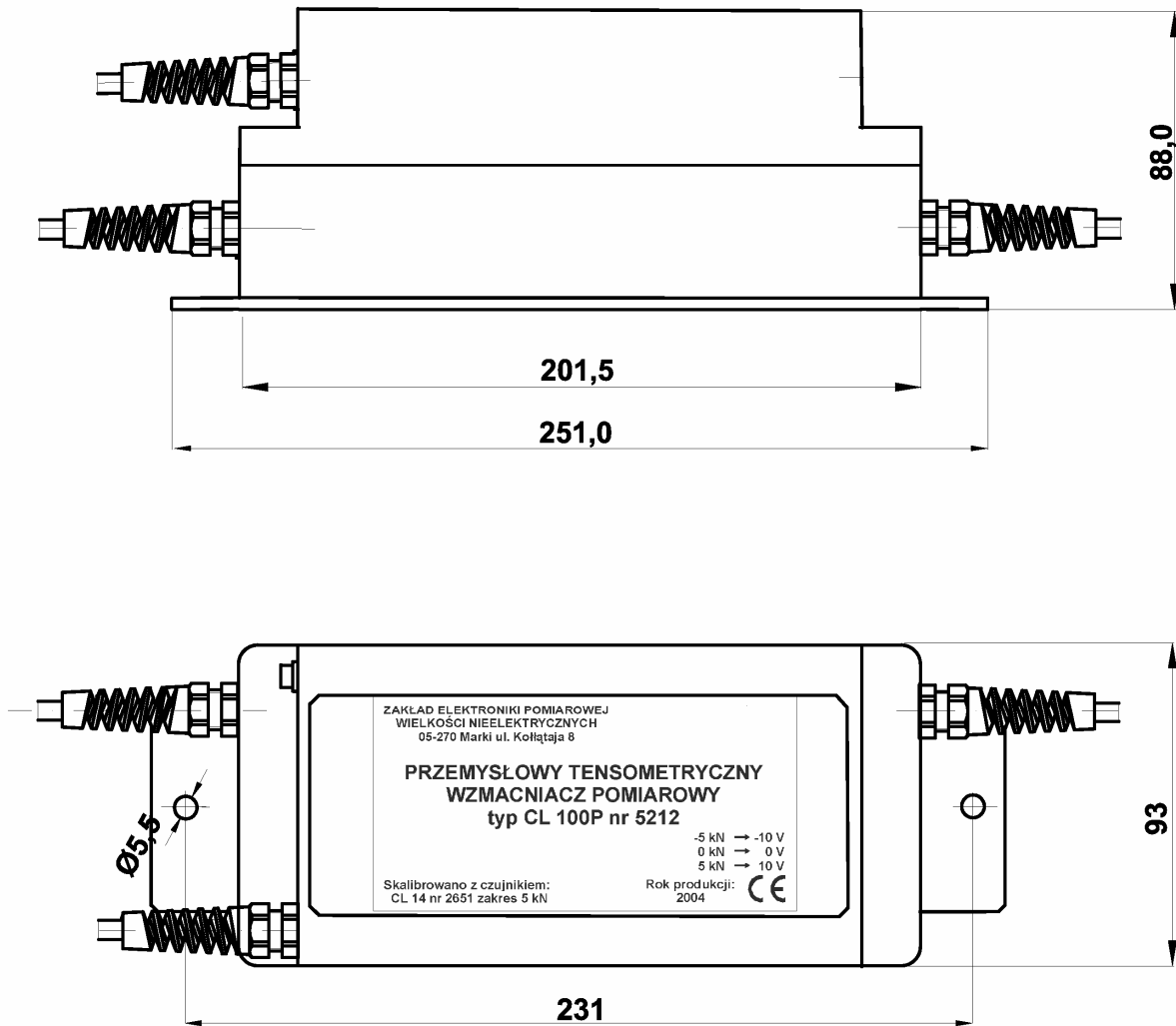

Manufacturer: \_\_\_\_\_

Zakład Elektroniki Pomiarowej Wielkości Nielektrycznych, 05-270 Marki, ul. Kołłątaja 8  
tel./fax: (004822) 7812169, 7712411, e-mail: [zepwn@zepwn.com.pl](mailto:zepwn@zepwn.com.pl), <http://www.zepwn.com.pl>