

REMOTE DISPLAY FOR WEIGHING



- Remote display for SMART, MATRIX II and SWIFT
- 7 digit weight LED 57 mm and 8 status LED. High bright.
- Stainless Steel enclosure IP65.
- Communication RS-232 and RS-485.

- External Power supply: 230 ± 10% V AC 50/60 Hz 12W.
- Mounting hardware included.

89316 Remote Display RD 60

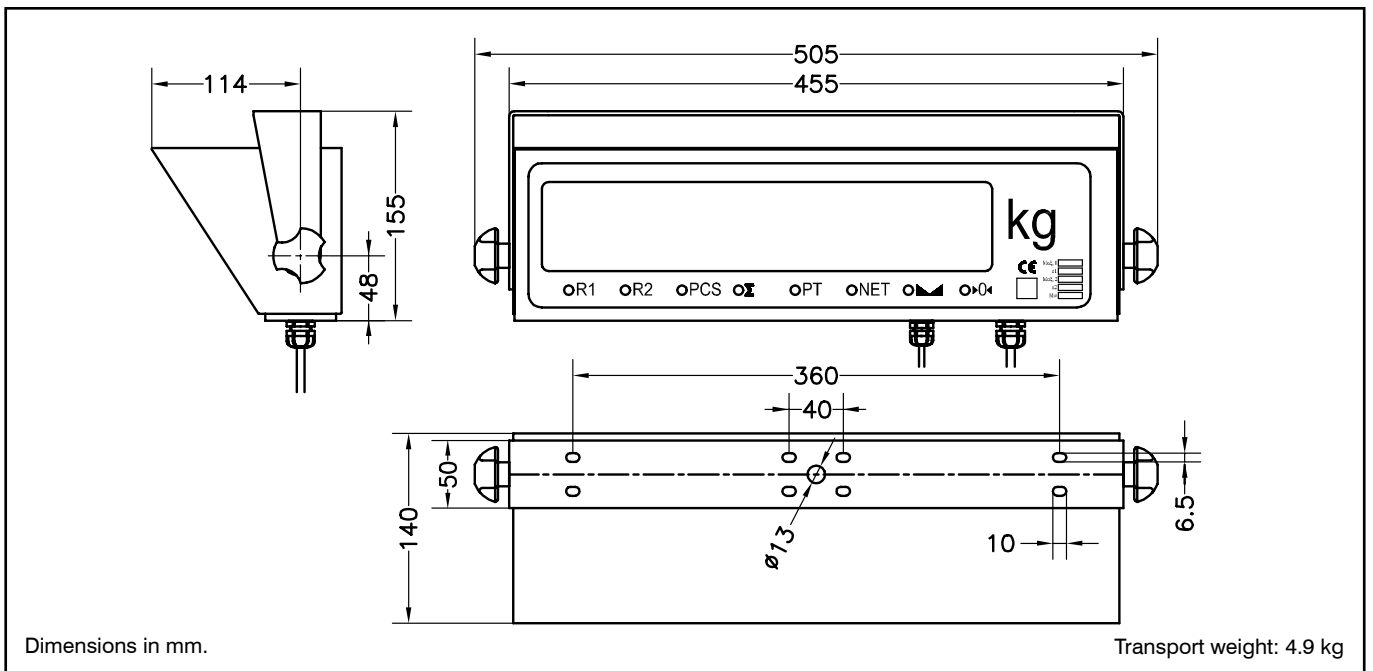

FERNANZEIGE FÜR WÄGETERMINAL



- Fernanzeige für SMART, MATRIX II und SWIFT.
- 7-stellige hellleuchtende 57mm LED Anzeige und 8 Status LEDs.
- Edelstahlgehäuse IP65.
- RS-232 und RS-485 Schnittstellen.

- Netzanschluss 230 ±10% V AC 50/60 Hz, 12W.
- Montagezubehör im Lieferumfang enthalten.
- Mehrsprachige Bedienungsanleitung.

89316 Fernanzeige RD 60

