

Force sensor CL 14

- high accuracy
- tension and compression load measurement
- three year warranty and after sales service

The force sensor CL 14 has been designed for measuring static and slow-changing forces. Together with ZEPWN instrumentation can find both labor and industrial usage, especially for converting force into electrical signal in industrial automatics and supervising systems. The sensor CL 14 can be load by tension or compression.



The conversion of measured load is realized due to a steel spring element with strain gage full bridge. The bridge is balanced and thermal compensated.

The sensor CL 14 in configurations R1, R2 has the strain gauge bridge 350 Ω with sensitivity 1 mV/V or 2 mV/V. For electrical protection IP40 the sensor is equipped with connectors. For electrical protection IP67 the sensor is equipped with stuffing on connection cable.

Specifications:

Range	[kN]:	0,05; 0,1; 0,5; 1; 2; 5; 10, 20, 50, 100
Configurations		R1, R2
Output signal	[mV/V]	1 - R1, 2 - R2
Accuracy		0,5 or 1 - (related to measurement results in range 10% - 100% of sensor total range)
Nominal supply voltage	[V]	10
Strain gage resistance	[Ω]	350
Input resistance	[Ω]	410 ± 10 (up to 10 kN) 380 ± 5 (20-100 kN)
Output resistance	[Ω]	350 ± 2
Zero point deviation	[%/30 min]	≤ 0,03
Return of output signal to zero after nominal load take away	[%]	≤ 0,03
Operating temperature	[°C]	+25 ± 10
Temperature effect on the sensitivity	[%/10K]	≤ 0,05
Temperature effect on the signal of unbalance	[%/10K]	≤ 0,05
Compensation temperature	[°C]	0 ÷ 90
Maximal strain	[mm]	0,5
Connectors		Z1 – LUMBERG or O1- O-ring gland
Protection degree		IP40, IP67
Dimensions		as in table below
Material		steel, aluminium
Cable length		3 m (standard) or other optional

Designations and cable outlets

1 brown	-W _y
2 pink	0 U _{zk}
3 white	0 U _z
4 yellow	+U _z
5 grey	+U _{zk}
6 green	+W _y
7 black	shield

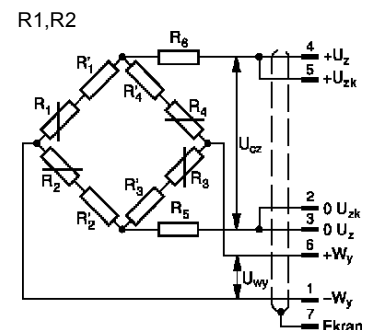

Classified force sensor CL 14

Quality assurance

Each sensor is detailed examined after manufacturing process.

The manufacturer offers 36 month warranty for the sensor and after that time also repair and calibration services.

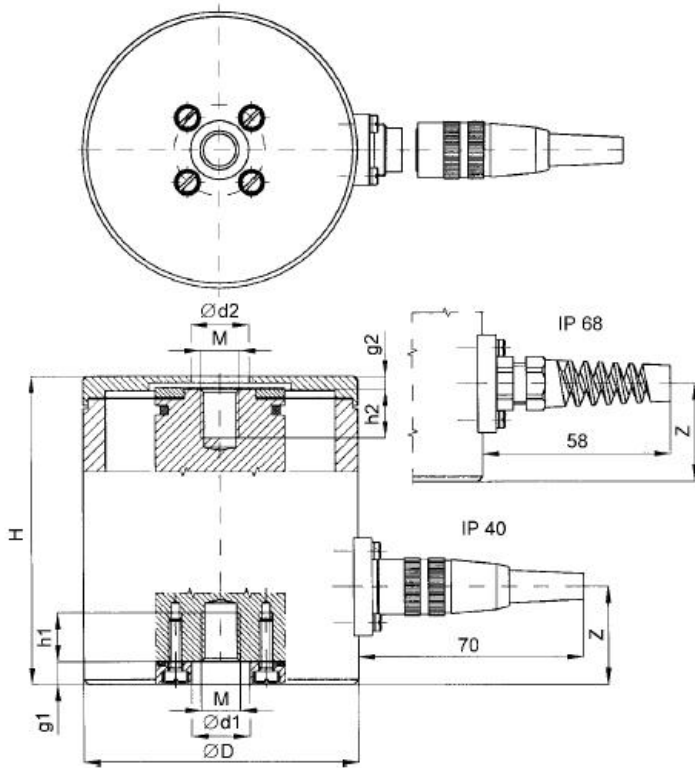

Range	H	D	Z	M	d1	g1	h1	d2	g2	h2
kN	mm									
0,05	75	65	22	M8	10	7	10	18	10	10
0,1	75	65	22	M8	10	7	10	18	10	10
0,2	75	65	22	M8	10	7	10	18	10	10
0,5	75	65	22	M8	10	7	10	18	10	10
1	75	65	22	M8	10	7	10	18	10	10
2	75	65	22	M8	10	7	10	18	10	10
5	93	85	30	M12	14	7	19	28	10	20
10	93	85	30	M12	14	7	19	28	10	20
20	97	88	30	M24x2	28	8	16	45	10	19
50	97	88	30	M24x2	28	8	16	45	10	19
100	140	126	50	M39x3	42	8	30	64	10	34

Options:

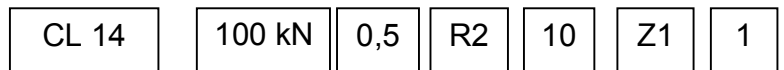

Range [kN]: 0,05; 0,1; 0,2; 0,5; 1; 2; 5; 10; 20; 50; 100;

Accuracy class: 0,5; 1

Configuration: R1 – bridge 350 Ω, 1 mV/V, R2 – 350 Ω, 2 mV/V

Supply voltage: 10 V

Connectors: Z1 – Lumberg DIN 45329; O1 – stuffing with stay wire

Cable length: standard 3 m or other optional

Example of options for ordering

CL 14 – 100 kN – 0,5 – R2 – 10- Z1 – 1: sensor with dimensions as in table, range 100 kN; accuracy 0,5; strain gauge bridge 350 Ω, 2 mV/V; supply 10 V; connector Lumberg; cable length 1 m

Manufacturer

ZEPWN J. Czerwiński i Wspólnicy sp.j., Poland, 05-270 Marki, ul. Kołtąja 8

tel./fax: 004822. 7812169, 7712411, e-mail: zepwn@zepwn.com.pl, <http://www.zepwn.com.pl>