



- Compression load cell, selfcentering column
- 4000 divisions O.I.M.L. R60 class C
- Available in **ATEX**  version (optional) Zone 0-1-2 (gas) and 20-21-22 (dust)
- Simple to install
- Stainless Steel construction
- Hermetically welded, protection class IP 68 (EN 60529) and IP 69K (ISO 20653)
- Pre-corner adjustment optimized for multicell systems
- Lightning protection
- Applications: High capacity weighing systems, truck scales
- Schwerlastwägezelle, selbstzentrierend
- 4000 Teile O.I.M.L. R60 Klasse C
- Erhältlich in **ATEX**  -Ausführung (optional) Zone 0-1-2 (Gas) und 20-21-22 (Staub)
- Einfache Montage
- Ausführung in Edelstahl
- Hermetisch dicht verschweißt Schutzart IP 68 (EN 60529) und IP 69K (ISO 20653)
- Abgeglicherer Ausgang für problemlose Parallelschaltung
- Blitzschutz
- Applikationen: Schwerlastwaagen, Strassenfahrzeugwaagen

Model Modell	Nominal capacity Nennlast Ln	Accuracy class Genauigkeitsklasse n. OIML	Minimum division Kleinster Teilungswert vmin	Safe load limit Grenzlast 150 % Ln	Breaking load Bruchlast > 350 % Ln
740 15 t	15 t	4000	1.5 kg	22.5 t	> 52.5 t
740 20 t	20 t	4000	2 kg	30 t	> 70 t
740 25 t	25 t	4000	2.5 kg	37.5 t	> 87.5 t
740 30 t	30 t	4000	3 kg	45 t	> 105 t
740 40 t	40 t	4000	4 kg	60 t	> 140 t
740 60 t	60 t	4000	6 kg	90 t	> 210 t



MODEL 740 +

ACC. 74901 (15...40 t)

ACC. 74905 (60 t)

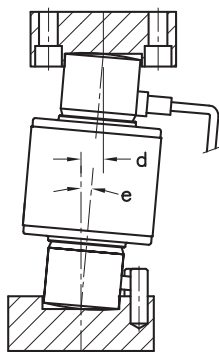
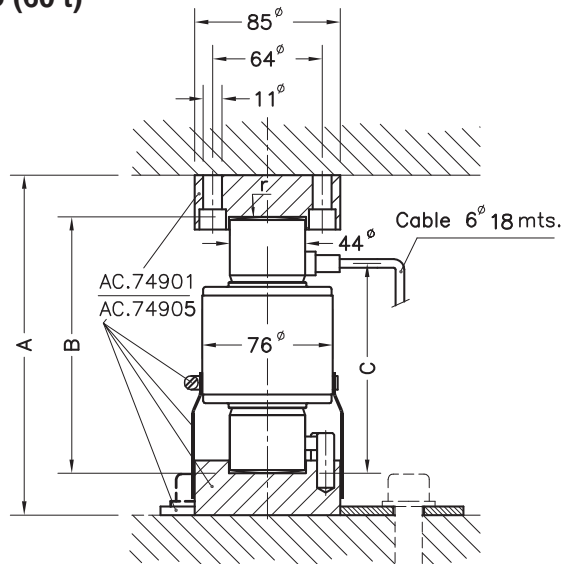
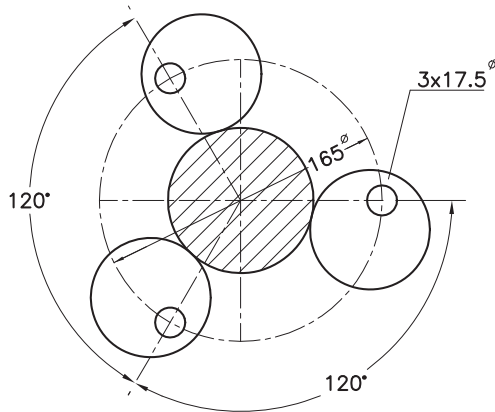

Load cells Wägezellen	A	B	C	d max.	e. max. Max. Neigung	Radius Ball r.	Transport Weight Transport- gewicht
740 15 t	200	150	123	13	5°	130	2.5 kg
740 20 t	200	150	123	13	5°	130	2.5 kg
740 25 t	200	150	123	13	5°	150	2.6 kg
740 30 t	200	150	123	13	5°	160	2.6 kg
740 40 t	200	150	123	13	5°	180	2.8 kg
740 60 t	260	210	153	11	3°	220	3.8 kg
Acc. 74901	---	---	---	---	---	---	3 kg
Acc. 74905	---	---	---	---	---	---	3 kg

Dimensions in mm. Abmessungen in mm.

SPECIFICATIONS		TECHNISCHE DATEN	
Nominal capacities (Ln)	15-20-25-30-40-60	t	Nennlasten (Ln)
Accuracy class	4000	n. OIML	Genauigkeitsklasse
Minimum dead load	0	%Ln	Minimale Vorlast
Service load	120	%Ln	Gebrauchslast
Safe load limit	150	%Ln	Grenzlast
Total error	< ±0.013	%Sn	Zusammengesetzter Fehler
Repeatability error	< ±0.015	%Sn	Wiederholgenauigkeit
Temperature effect: on zero	< ±0.01	%Sn/5°K	Temperaturfehler: Nullpunkt
on sensitivity	< ±0.006	%Sn/5°K	Kennwert
Creep error (30 minutes)	< ±0.012	%Sn	Kriechfehler (30 min)
Temperature compensation	-10...+40	°C	Nenntemperaturbereich
Temperature limits	-50...+70	°C	Arbeitstemperaturbereich
Nominal sensitivity (Sn)	2	mV/V (1)	Nennkennwert (Sn)
Nominal input voltage	10	V	Nom. Speisespannung
Maximum input voltage	15	V	Max. Speisespannung
Input impedance	800 ±5	Ω	Eingangswiderstand
Output impedance	705 ±5	Ω	Ausgangswiderstand
No load output	±2	%Sn	Nullsignaltoleranz
Insulation resistance	> 5000	MΩ	Isolationswiderstand
Maximum deflection (at Ln)	0.6-1	mm	Nennmessweg (bei Ln)

(1) Pre-corner adjustment optimized at ±0.05% by output current calibration /
Auf ±0.05% optimierter Eckenvorabgleich durch Stromkalibrierung des Ausgangssignals

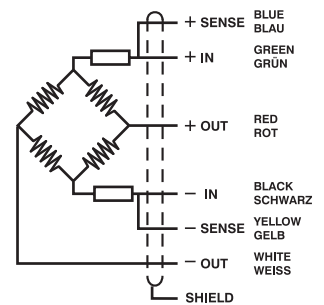

**ELECTRICAL CONNECTION
ELEKTRISCHER ANSCHLUSS:**

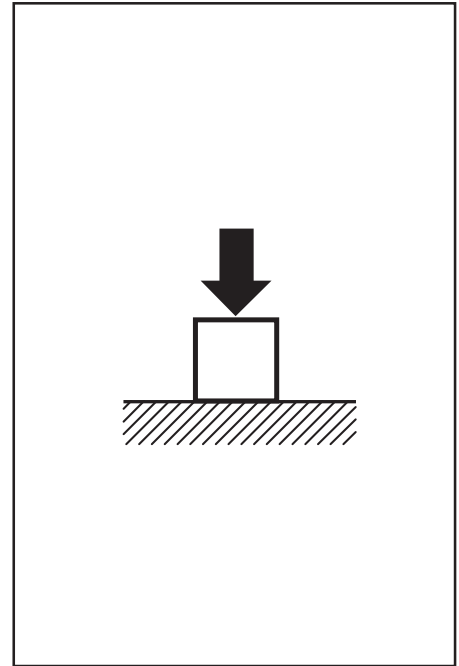

«SENSES»: 2 additional wires to maintain a constant voltage supply at the load cell when used with proper instrumentation. Use specially when long wires and wide temperature range.
SHIELD: Not connected to transducer body.

"SENSE-Leitung": zwei zusätzliche Adern, um eine konstante Spannungsversorgung an der Wägezelle zu gewährleisten, wenn entsprechende Elektronik verwendet wird. Speziell bei langen Leitungen und grossem Temperaturunterschied auf der Leitung.
SCHIRM: nicht am Wägezellenkörper angeschlossen.



- Compression load cell, selfcentering column
 - 1000 divisions O.I.M.L. R60 class C
 - Available in **ATEX**  version (optional) Zone 0-1-2 (gas) and 20-21-22 (dust)
 - Simple to install
 - Stainless Steel construction
 - Hermetically welded, protection class IP 68 (EN 60529) and IP 69K (ISO 20653)
 - Pre-corner adjustment optimized for multicell systems
 - Lightning protection
 - Applications: High capacity weighing systems
- Schwerlastwägezelle, selbstzentrierend
 - 1000 Teile O.I.M.L. R60 Klasse C
 - Erhältlich in **ATEX**  -Ausführung (optional) Zone 0-1-2 (Gas) und 20-21-22 (Staub)
 - Einfache Montage
 - Ausführung in Edelstahl
 - Hermetisch dicht verschweißt Schutzart IP 68 (EN 60529) und IP 69K (ISO 20653)
 - Abgeglichener Ausgang für problemlose Parallelschaltung
 - Blitzschutz
 - Applikationen: Schwerlastwaagen

Model Modell	Nominal capacity Nennlast Ln	Accuracy class Genauigkeitsklasse n. OIML	Minimum division Kleinster Teilungswert vmin	Safe load limit Grenzlast 150% Ln	Breaking load Bruchlast
740 100 t	100 t	1000	15 kg	150 t	350 t
740 200 t	200 t	1000	30 kg	300 t	450 t
740 400 t	400 t	1000	60 kg	600 t	1200 t
740 600 t	600 t	1000	90 kg	900 t	1800 t



MODEL 740 +

ACC. 74904 (100 t...200 t)

ACC. 74911 (400 t)

ACC. 74912 (600 t)

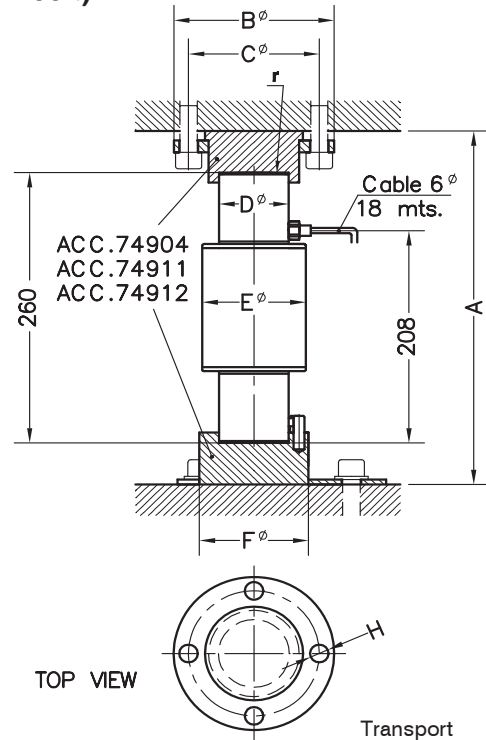
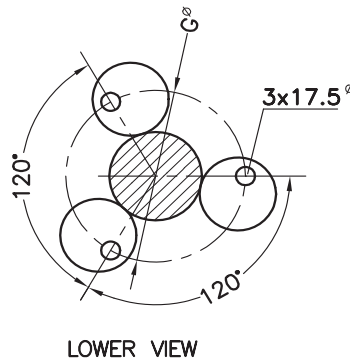
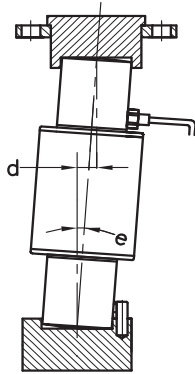

Load cells Wägezellen	A	B	C	D ϕ	E ϕ	F	G	H	d max.	e. max. Max. Neigung	Radius Ball r.	Transport- gewicht
740 100 t	340	147	120	64	104	100	165	17	18	4°	290	11 kg
740 200 t	340	147	120	64	104	100	165	17	9	2°	400	11 kg
740 400 t	400	220	190	109	140	160	200	21	8	1.4°	700	23 kg
740 600 t	440	220	190	118	140	160	200	21	8	1.4°	800	27 kg
Acc.74904	-	-	-	-	-	-	-	-	-	-	-	7 kg
Acc.74911	-	-	-	-	-	-	-	-	-	-	-	27 kg
Acc.74912	-	-	-	-	-	-	-	-	-	-	-	36 kg

Dimensions in mm. Abmessungen in mm.

SPECIFICATIONS			TECHNISCHE DATEN
Nominal capacities (Ln)	100-200- 400-600	t	Nennlasten (Ln)
Accuracy class	1000	n. OIML	Genauigkeitsklasse
Minimum dead load	0	%Ln	Minimale Vorlast
Service load	120	%Ln	Gebrauchslast
Safe load limit	150	%Ln	Grenzlast
Total error	0.05	%Sn	Zusammengesetzter Fehler
Repeatability error	0.015	%Sn	Wiederholgenauigkeit
Temperature effect: on zero	0.01	%Sn/5°K	Temperaturfehler: Nullpunkt
on sensitivity	0.018	%Sn/5°K	Kennwert
Creep error (30 minutes)	0.048	%Sn	Kriechfehler (30 min)
Temperature compensation	-10...+40	°C	Nenntemperaturbereich
Temperature limits	-50...+70	°C	Arbeitstemperaturbereich
Nominal sensitivity (Sn)	2 ±0.5%	mV/V	Nennkennwert (Sn)
Nominal input voltage	10	V	Nom. Speisespannung
Maximum input voltage	15	V	Max. Speisespannung
Input impedance	800 ±5	Ω	Eingangswiderstand
Output impedance	705 ±5	Ω	Ausgangswiderstand
No load output	±2	%Sn	Nullsignaltoleranz
Insulation resistance	> 5000	M Ω	Isolationswiderstand
Maximum deflection (at Ln)	1.2-2.6	mm	Nennmessweg (bei Ln)

**ELECTRICAL CONNECTION
ELEKTRISCHER ANSCHLUSS:**

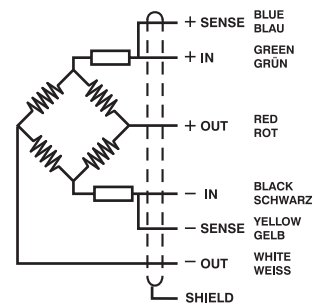

«SENSES»: 2 additional wires to maintain a constant voltage supply at the load cell when used with proper instrumentation. Use specially when long wires and wide temperature range.
SHIELD: Not connected to transducer body.

"SENSE-Leitung": zwei zusätzliche Adern, um eine konstante Spannungsversorgung an der Wägezelle zu gewährleisten, wenn entsprechende Elektronik verwendet wird. Speziell bei langen Leitungen und grossem Temperaturunterschied auf der Leitung.
SCHIRM: nicht am Wägezellenkörper angeschlossen.

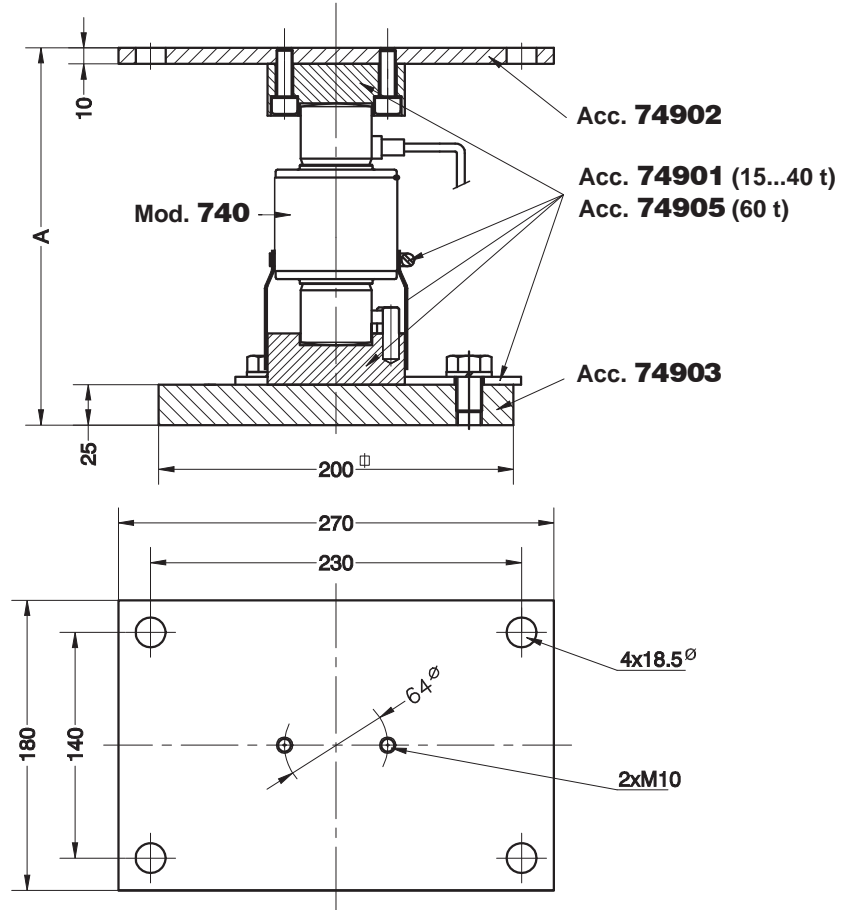
ACCESSORIES FOR MODEL 740 (15...60t)
ZUBEHÖR FÜR MODELL 740 (15...60t)

Accessory Zubehör	Model Modell	A	Accessory Zubehör	Transport Weight Transport- gewicht
74901 + 74902 + 74903	740 (15-20-25-30-40 t)	235	74901	3 kg
74905 + 74902 + 74903	740 (60 t)	295	74902	3.9 kg
			74903	9.7 kg
			74905	3 kg

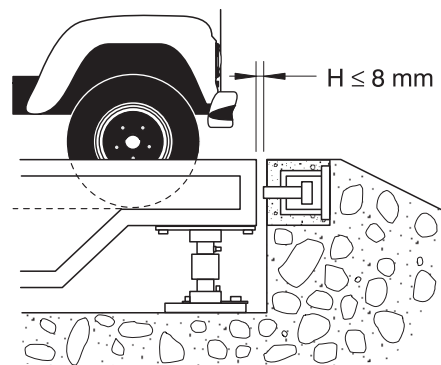
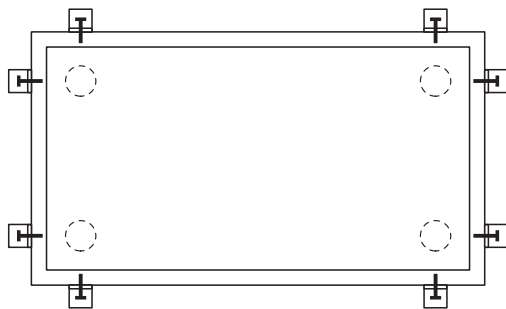

Dimensions in mm. Abmessungen in mm.

MOUNTING KIT LIFT-OFF PREVENTION FOR SILO FOR M.740 (15...40t)
LASTECKE MIT ABHEBESICHERUNG FÜR M.740 (15...40t)

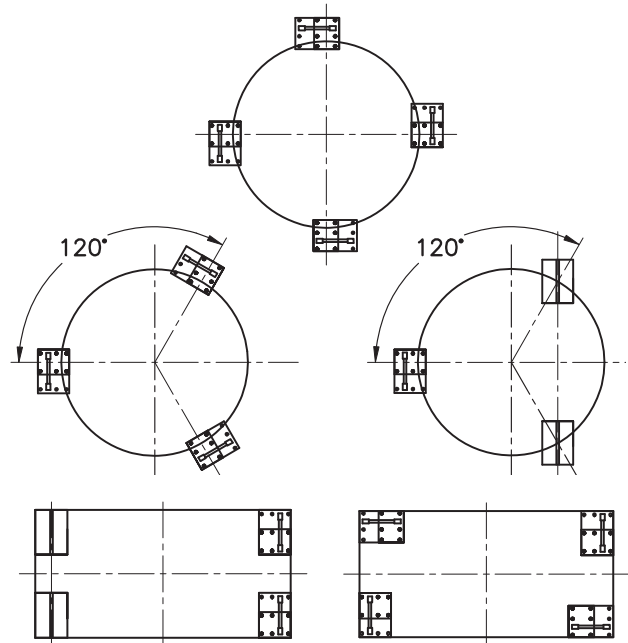
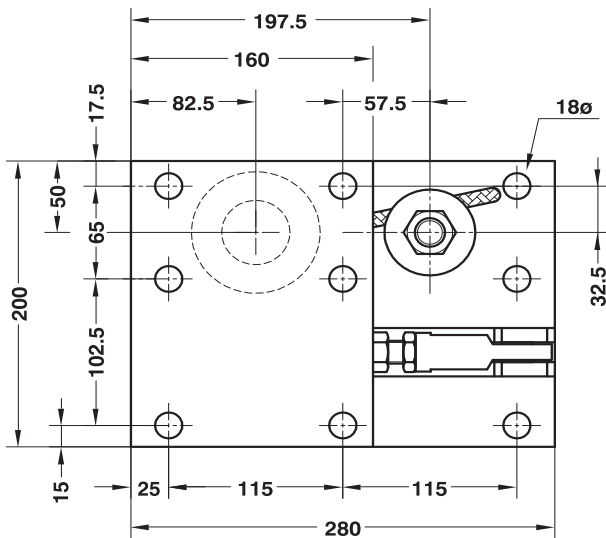
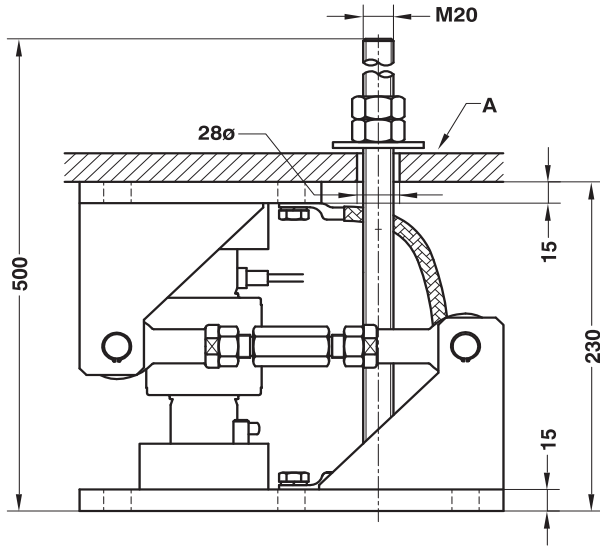

Nominal load	15...40 t	Nennlast
Max. permissible side offset transverse to retention arm	±4 mm	Max. zulässige Seitenverschiebung zur Lenkerrichtung
Permissible horitz. force in direction of the retention arm	47 kN	Max. zulässige Horizontalkraft zur Lenkerrichtung
Maximum permissible lifting force	76 kN	Max. zulässige Zugkraft vertikal
Max. permissible lifting movement, must be adjusted (A)	3 mm	Max. zulässiger Nennweg vertikal, muss eingestellt werden (A)
Material: Steel alloy zinc-plated		Material: Verzinkter Stahl

Dimensions in mm. Abmessungen in mm.

Transport weight - Transportgewicht: 19 kg

**MOUNTING KIT LIFT-OFF PREVENTION FOR SILO FOR M.740 (60t)
LASTECKE MIT ABHEBESICHERUNG FÜR M.740 (60t)**

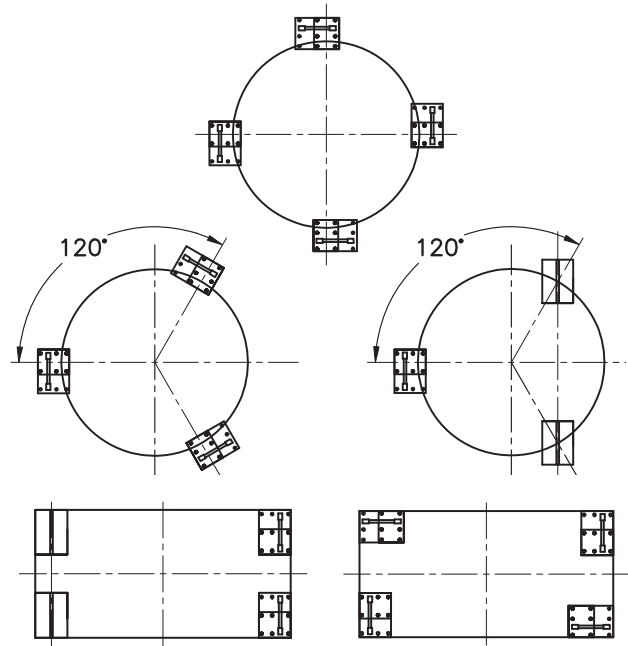
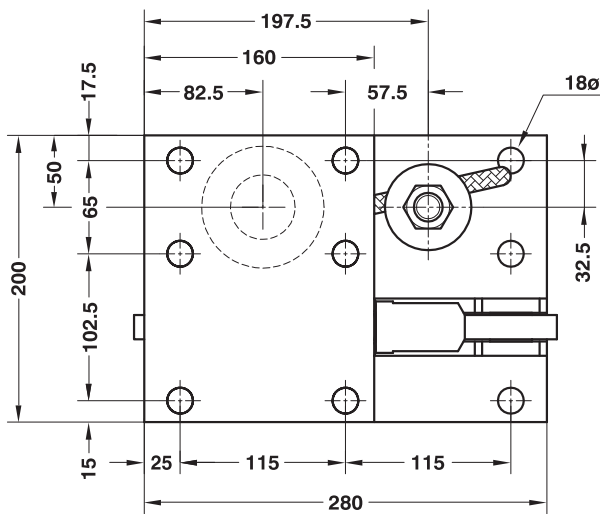
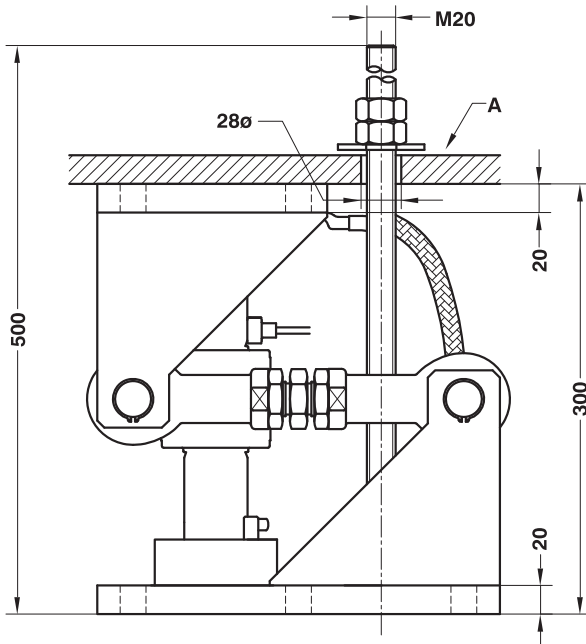

Nominal load	60 t	Nennlast
Max. permissible side offset transverse to retention arm	±4 mm	Max. zulässige Seitenverschiebung zur Lenkerrichtung
Permissible horitz. force in direction of the retention arm	95 kN	Max. zulässige Horizontalkraft zur Lenkerrichtung
Maximum permissible lifting force	114 kN	Max. zulässige Zugkraft vertikal
Max. permissible lifting movement, must be adjusted (A)	3 mm	Max. zulässiger Nennweg vertikal, muss eingestellt werden (A)
Material: Steel alloy zinc-plated		Material: Verzinkter Stahl

Dimensions in mm. Abmessungen in mm.

Transport weight - Transportgewicht: 27 kg

MOUNTING KIT LIFT-OFF PREVENTION FOR SILO FORM. 740 (100...200t) LASTECKE MIT ABHEBESICHERUNG FÜR M.740 (100...200t)

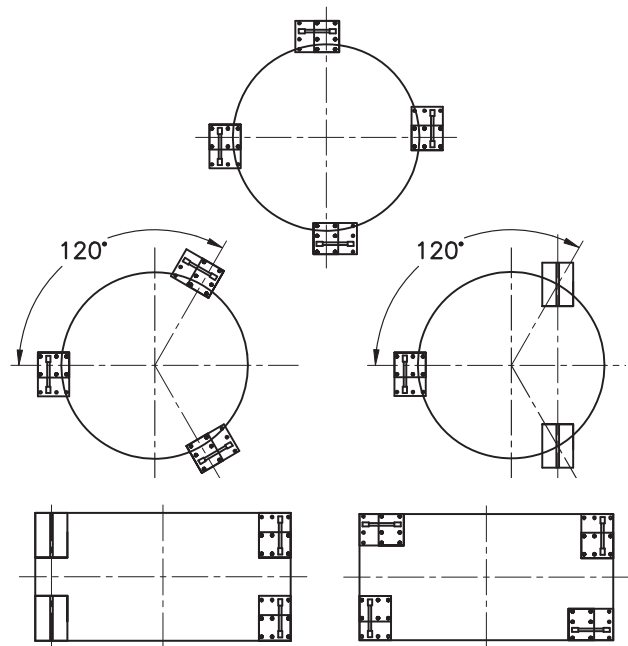
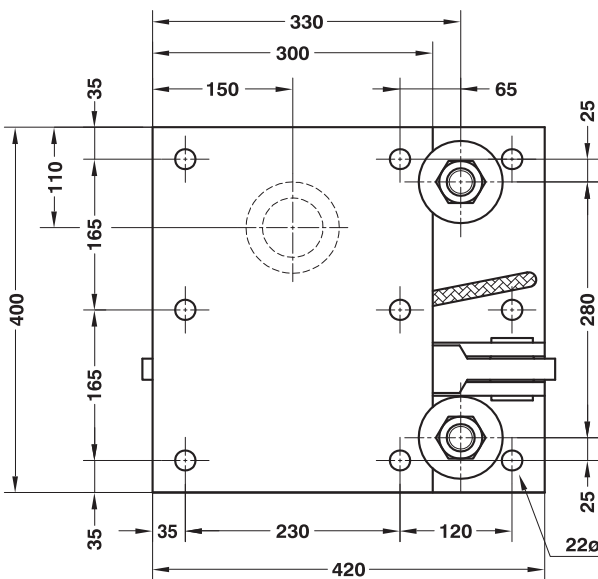
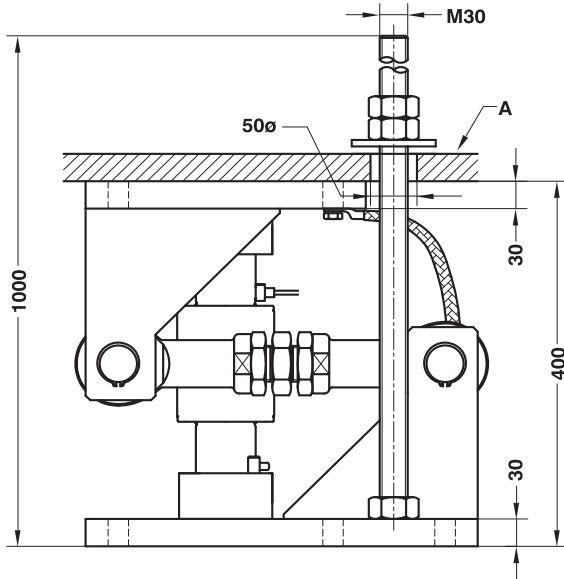

Nominal load	100...200 t	<i>Nennlast</i>
Max. permissible side offset transverse to retention arm	±5 mm	<i>Max. zulässige Seitenverschiebung zur Lenkerrichtung</i>
Permissible horitz. force in direction of the retention arm	180 kN	<i>Max. zulässige Horizontalkraft zur Lenkerrichtung</i>
Maximum permissible lifting force	228 kN	<i>Max. zulässige Zugkraft vertikal</i>
Max. permissible lifting movement, must be adjusted (A)	3 mm	<i>Max. zulässiger Nennweg vertikal, muss eingestellt werden (A)</i>
Material: Steel alloy zinc-plated		<i>Material: Verzinkter Stahl</i>

 Dimensions in mm. *Abmessungen in mm.*

 Transport weight - *Transportgewicht:* 98 kg

MOUNTING KIT LIFT-OFF PREVENTION FOR SILO FOR M.740 (400t) LASTECKE MIT ABHEBESICHERUNG FÜR M.740 (400t)

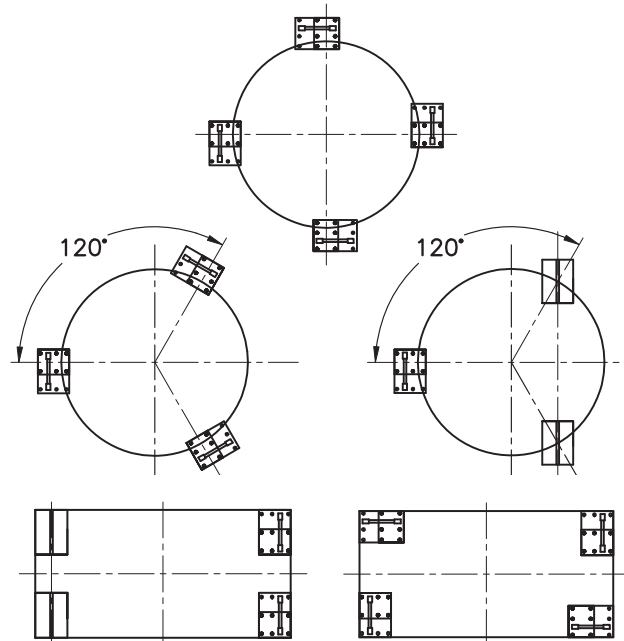
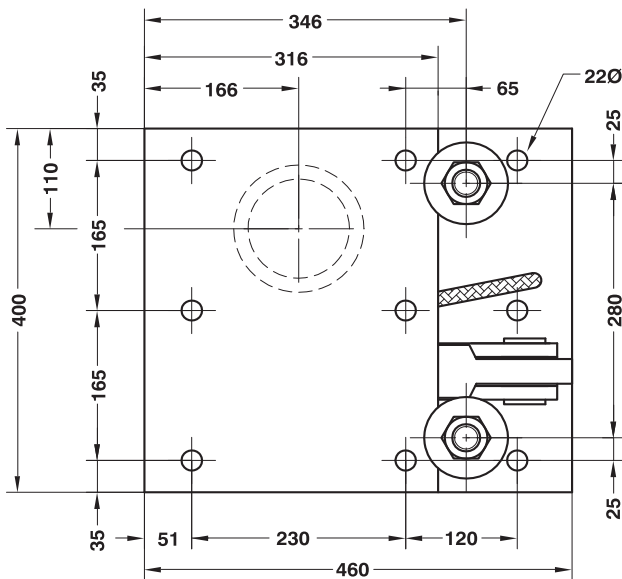
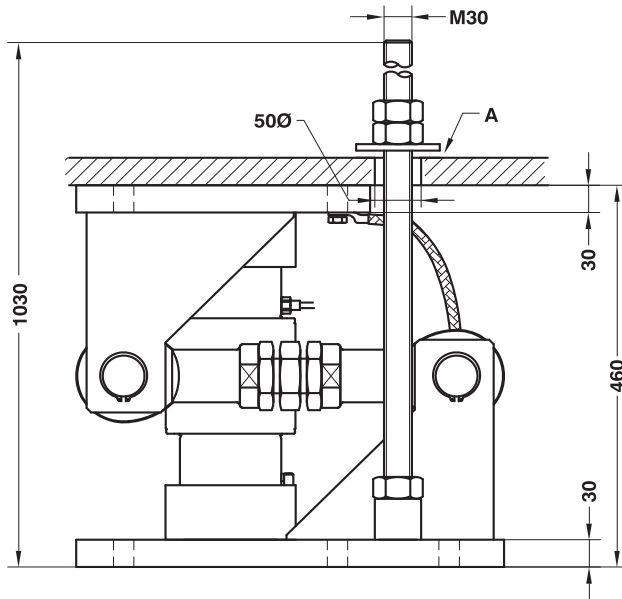

Nominal load	400 t	Nennlast
Max. permissible side offset transverse to retention arm	±5 mm	Max. zulässige Seitenverschiebung zur Lenkerrichtung
Permissible horitz. force in direction of the retention arm	240 kN	Max. zulässige Horizontalkraft zur Lenkerrichtung
Maximum permissible lifting force	330 kN	Max. zulässige Zugkraft vertikal
Max. permissible lifting movement, must be adjusted (A)	3 mm	Max. zulässiger Nennweg vertikal, muss eingestellt werden (A)
Material: Steel alloy zinc-plated		Material: Verzinkter Stahl

Dimensions in mm. Abmessungen in mm.

Transport weight - Transportgewicht: 142 kg

MOUNTING KIT LIFT-OFF PREVENTION FOR SILO FOR M.740 (600t) LASTECKE MIT ABHEBESICHERUNG FÜR M.740 (600t)

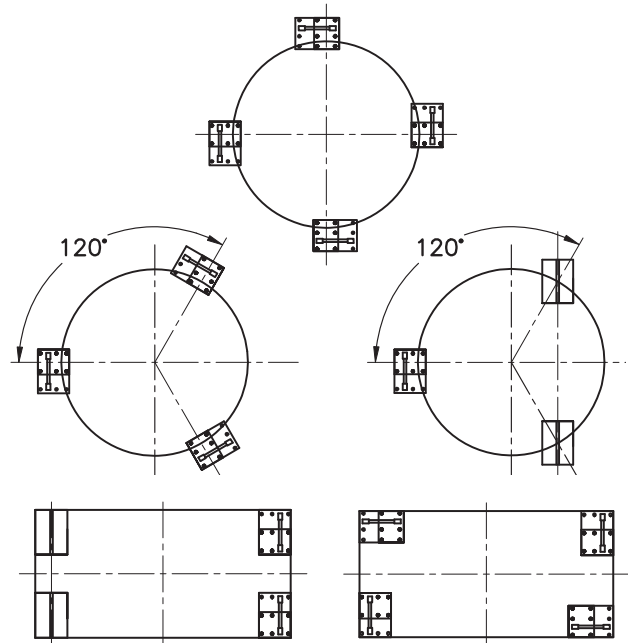
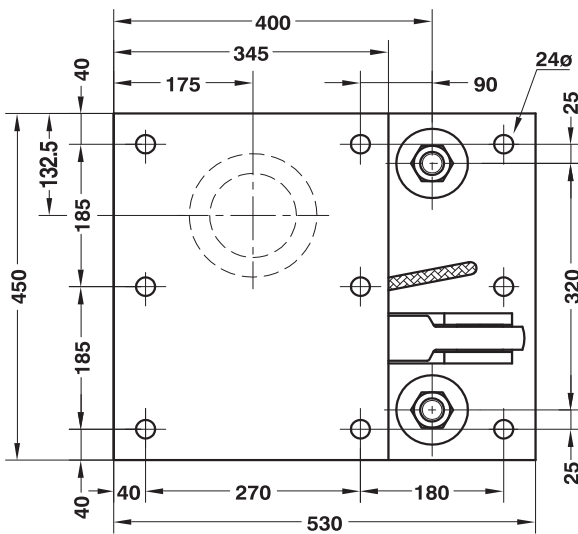
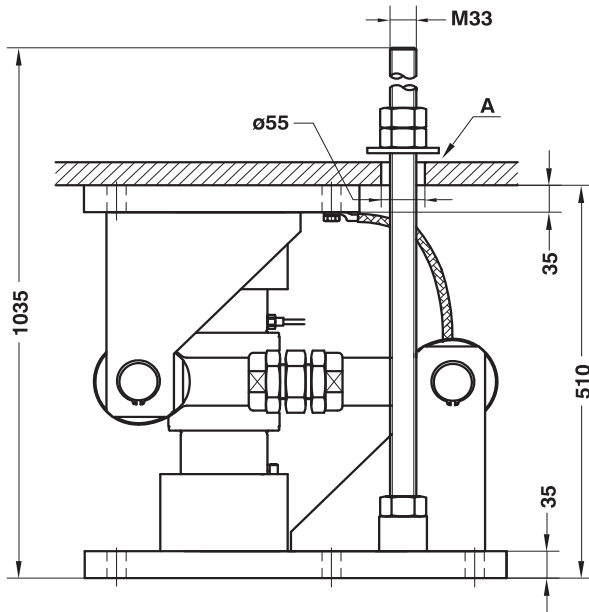

Nominal load	600 t	Nennlast
Max. permissible side offset transverse to retention arm	±5 mm	Max. zulässige Seitenverschiebung zur Lenkerrichtung
Permissible horitz. force in direction of the retention arm	290 kN	Max. zulässige Horizontalkraft zur Lenkerrichtung
Maximum permissible lifting force	395 kN	Max. zulässige Zugkraft vertikal
Max. permissible lifting movement, must be adjusted (A)	3 mm	Max. zulässiger Nennweg vertikal, muss eingestellt werden (A)
Material: Steel alloy zinc-plated		Material: Verzinkter Stahl

Dimensions in mm. Abmessungen in mm.

Transport weight - Transportgewicht: 185 kg